

Compact capacitance level transmitter with settable relay built-in

Technical Data

Enclosure material:	Nylon + metallized Nylon
Mechanical installation:	Bajonet (to be insert into IP65 enclosure)
Mechanical protection:	IP50
Electrical connection:	2 x 6pole plug-in connectors
Working temperature:	-30 to +80°C
Power supply depend to the model:	TC26 24Vdc, TC27 24Vac, TC28 115Vac, TC29 230Vac
Power consumption:	max 2,5W (1,5W Vdc)
Analog output:	4÷20mA max load 500 ohm
Relays output:	1 x SPDT 2A, 230Vac (resistive)
Serial port:	RS485
Measure range:	20pF÷10.000pF
Temperature compensation:	by ref. internal capacitor
Linearity:	0,5%
Calibration:	two push-buttons, for self-acquisition
LEDs display:	green LED flashing=measure Fix=calibration yellow LEDs for rel1 action

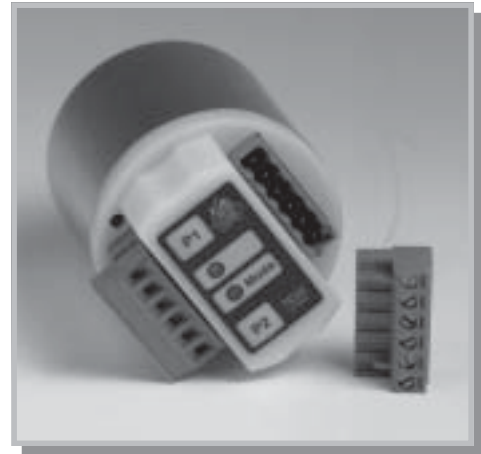

TC26-9 General

LEVEL 4-20mA transmitter + 1 settable relay insert, digital technology, thermal-drift compensation, two pushbuttons or RS485 port for calibration. Local or remote calibration possibility.

COMPACT VERSION

fig.1

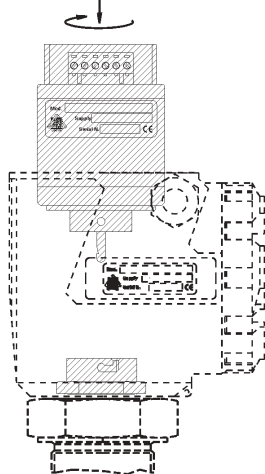

TC26-9 Mechanical installation

The TC26-9 insert must lodge into the IP65 capacitance-sensor head connection.
Important to screw tight the cover of the head connection and the cable gland in order to grant the sensor IP65.
Thanks to the bajonet fixing-system, to insert or remove the TC26-9 from the head connection need to push and rotate. Rotate clock-wise to fix into the head
Rotate reverse-clock-wise to remove from the head

SEPARATE-ELECTRODE VERSION

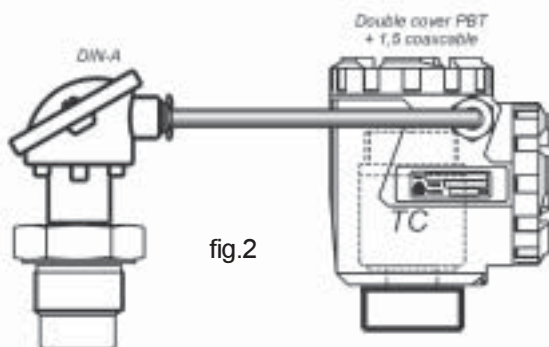
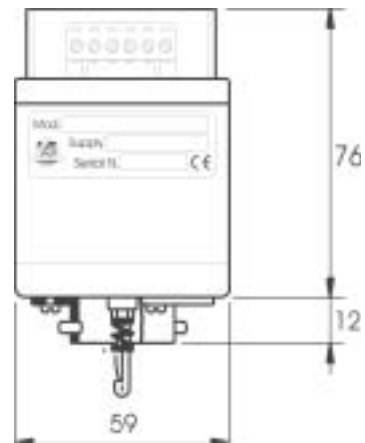

fig.2

fig.3



TC26-9 Electrical Connections

The TC26-9 capacitance transmitters have the following power-supply, electrical connections:

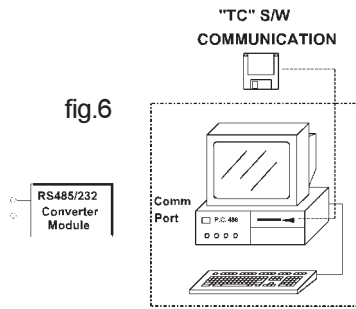
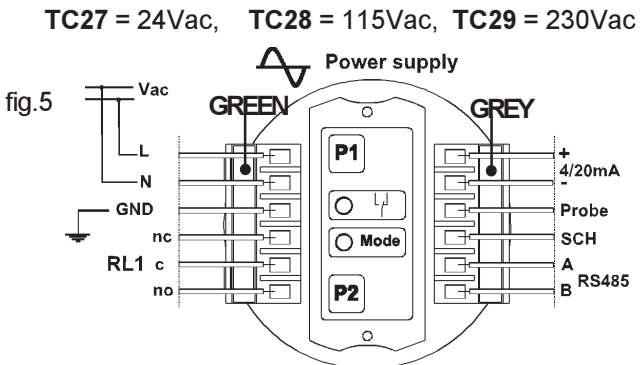
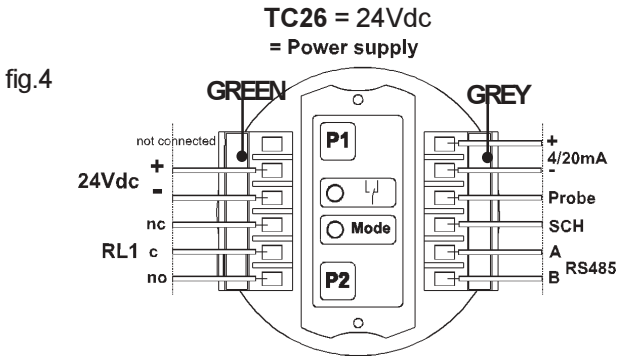

The current consumption is less than 1,5W for Vdc power supply and 2,5W for Vac power supply.

The TC26-29 capacitance transmitters are lodged into the sensor capacitance head connections; remove the cover unscrewing and opening the upper part, gain the access to two 6-pole plug-in connectors. Electrical connection must be made with a multi-wires round cable of proper diameter, otherwise the seal of the cable gland may be impaired. **No special cable or coax-cable are requests for compact version, and no practice distance limits.** For the Vdc power supply take in consideration that the negative of the power supply is electrically connected to the negative output current. For the Vac power supply versions, from the power supply and the output current there is a galvanically separation. A special J-box with P1 and P2 calibration push buttons built-in is available on request for remote-calibration.

Available a RS485 serial port to communicate to PC or PLC. On request the "TC" S/W communication for PC and the RS485/RS232 conversion module are available. "TC" allow a PCTC26-29 configuration and calibration, see the relevant documentation.

Always connect the electrode to vessel ground (PA). For this purpose there is a terminal on the side of the housing or on the mechanical connection. This connection is also used to supply the ground reference potential as well as to drain off electrostatic charges.

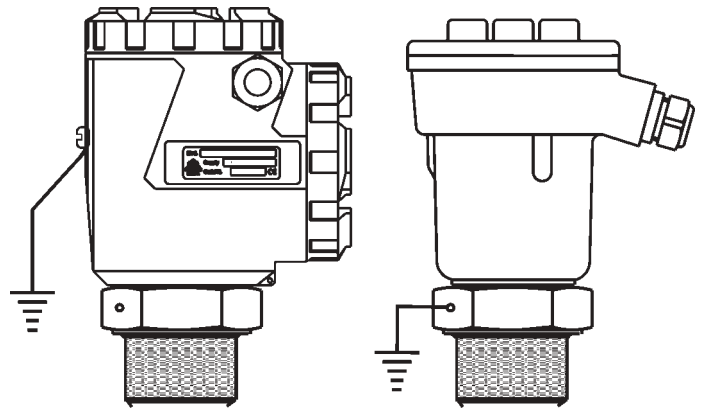

TC26-9 Setpoint Calibration

The TC26-9 relay (RL1) operates as max level alarm (threshold1). This configuration is the default factory configuration and it can be changed by means RS485 port and the TC S/W communication.

To calibrate the threshold1 of maximum level needs to move the level at the threshold point than: press simultaneously P1 and P2, release them and verify that "Mode led" will stay fix on. Press P2 and release it, press P1 and release it. Wait until "Mode led" is flashing again before move the level. The threshold of RL1 has been memorised.

On fig.7 the relay status.

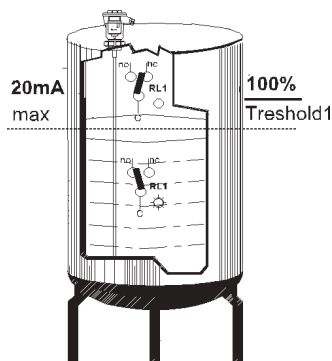
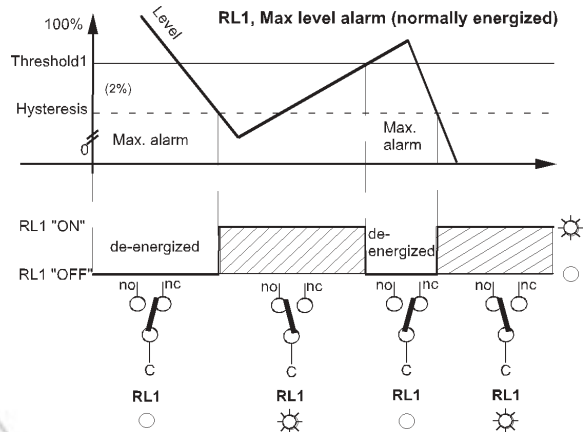

fig.7



The TC26-9 calibration can be done in two different ways:

- a) By means the P1 and P2 push-buttons.
- b) With PC or PLC soft. communication with RS485 port.

a)

To calibrate by-means 2 push-buttons P1 and P2 (see figure), needs to lodge the “TC26-29” into the head connection of the capacitance sensor and to install into the vessel or tank to be measured.

Depends to the possibility to reach easily 0% and 100% level is possible to use “Full-Empty Calibration” or , when 0% and 100% level can't be reached the “High and Low-point Calibration” methods can be used, see fig.8.

Full, Empty Calibration(fig.9)

The TC26-9 transmitter can be calibrate in respectively at the level of 0% and 100% level, in order to memorise the relevant capacity electronically.

In the measuring mode, the TC has the Mode LED flashing.

To calibrate 0% (4mA) needs to have the level at the 0%.

Press simultaneously P1 and P2, release them and verify that “Mode led” will stay fix lightened.

Press two times P1. The measured capacity has been memorised and associated to 4mA output.

Press simultaneously P1 and P2 again to switch in measure mode (Mode led flashing).

To calibrate 100% (20mA) needs to have the level at the 100%.

Press simultaneously P1 and P2, release them and verify that “Mode led” will stay fix lightened.

Press two times P2. The measured capacity has been memorised and associated to 20mA output.

Press simultaneously P1 and P2 again to switch in measure mode (Mode led flashing).

Important!

The calibration can be done first with empty and than with full (as the above procedure) or first with full and than with empty as well.

b)

Refers to the “TC” S/W operating manual

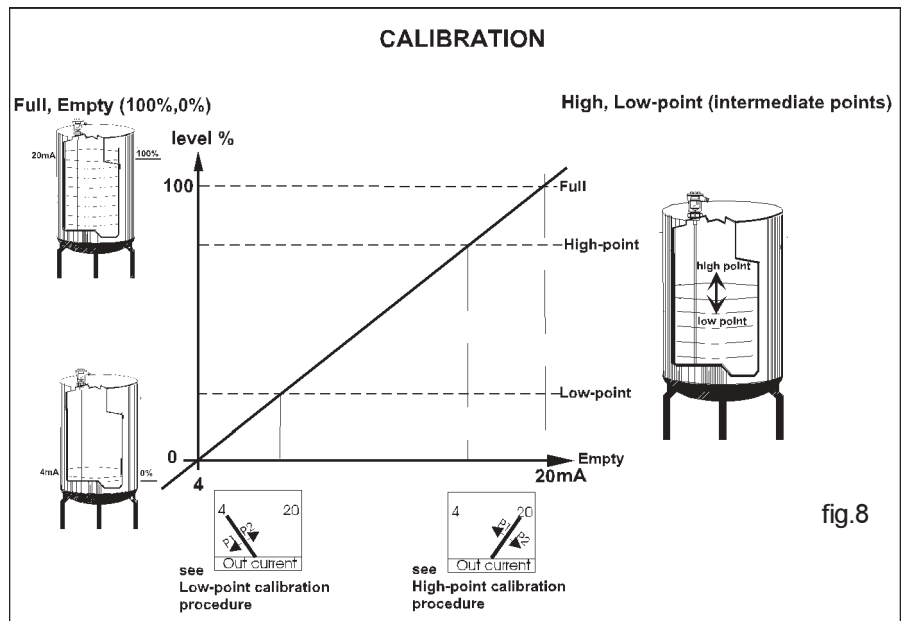

fig.8

Full(100%), Empty(0%) Calibration

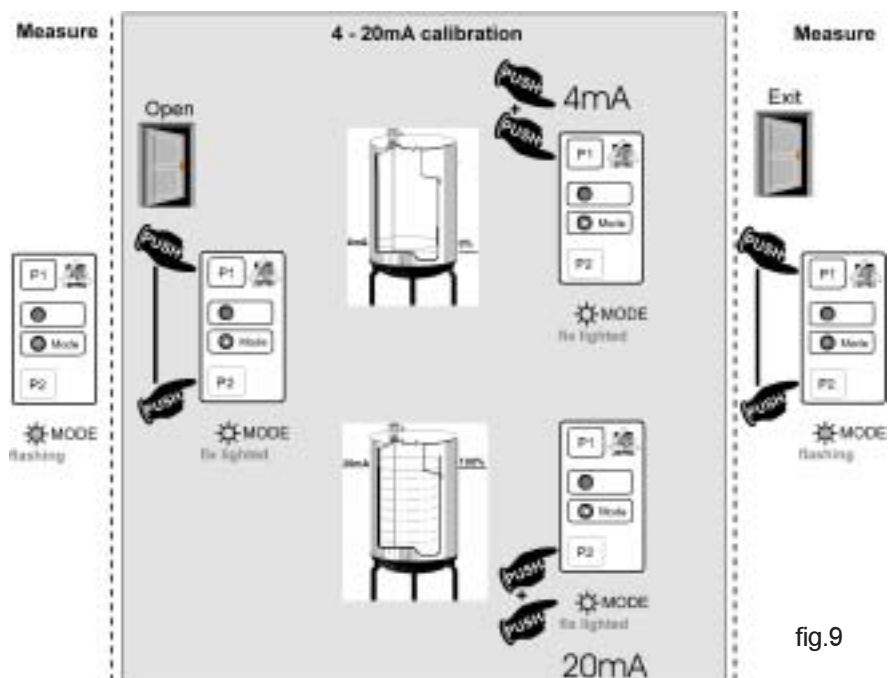

fig.9

TC26-9 4-20mA Calibration (intermediate High-point , Low-point)

High-point, Low-point Calibration

If only a limited level variation is possible, the calibration of the TC26-9 is still possible.

Need to connect a current-meter on the TC26-9 output current and verify the present level point at which make the calibration. Supposedly you are on the Low-point calibration, and the relevant level is 26%(8,16mA) than;

Press simultaneously P1 and P2, release them and verify that "Mode led" will stay fix lightened, Open the calibration mode. Press two times P1. The measured capacity has been associated at the moment to 4mA output. Now, pushing few times the P2 key, increase the output current from 4mA to 8,16mA, (P1 decrease the value). Once the correct current-output is displayed in to the current meter; press simultaneously P1 and P2 again to Exit from calibration going in measure mode (Mode led flashing).

Increase the level of your product as much as possible, for instance up to 58%(13,28mA) than;

Press simultaneously P1 and P2, release them and verify that "Mode led" will stay fix lightened, Open the calibration mode. Press two times P2. The measured capacity has been associated at the moment to 20mA output. Now, pushing few times the P1 key, decrease the output current from 20mA to 13,28mA, (P2 increase the value) ; press simultaneously P1 and P2 again to Exit from calibration going in measure mode (Mode led flashing).

Important!

The calibration can be done first with low-point and than with high-point (as the above procedure) or first with high-point and than with low-point as well.

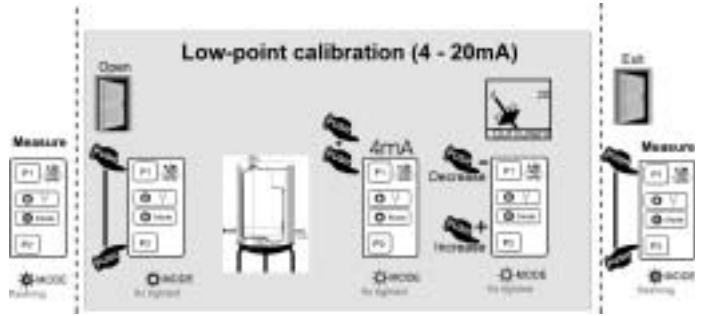

fig.10

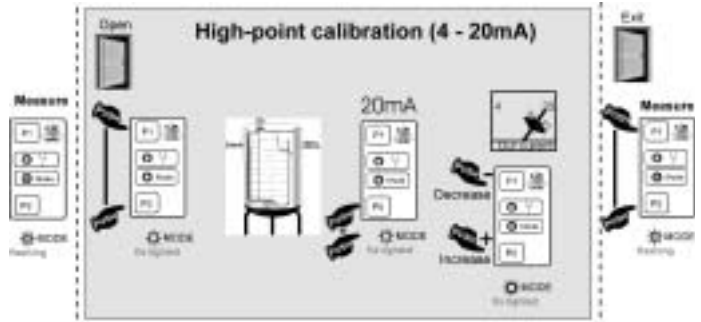

fig.11

TC26-9 Warranty

Products supplied by SGM LEKTRA are guaranteed for a period of 12 (twelve) months from delivery date according to the conditions specified in our sale conditions document. SGM LEKTRA can choose to repair or replace the Product. If the Product is repaired it will maintain the original term of guarantee, whereas if the Product is replaced it will have 12 (twelve) months of guarantee. The warranty will be null if the Client modifies, repair or uses the Products for other purposes than the normal conditions foreseen by instructions or Contract. In no circumstances shall SGM LEKTRA be liable for direct, indirect or consequential or other loss or damage whether caused by negligence on the part of the company or its employees or otherwise howsoever arising out of defective goods.

TC26-9 Factory test certificate

In conformity to the company and check procedure I certify that the equipment:

TC2 Serial n.

is conform to the technical requirements on Technical Data and it is made in conformity to the SGM-LEKTRA procedure

Quality Control Manager

Production and check date



LEKTRA
KEMA CERTIFICATE



SGM LEKTRA s.r.l.

Via Papa Giovanni XXIII, 49
20090 Rodano (Milano)
tel. ++39 0295328257 r.a.
fax ++39 0295328321
e-mail: info@sgm-lektra.com
web: www.sgm-lektra.com