

# TC30

825B046F-Ex

Compact capacitance level transmitter with ATEX EEx ia IIC T4...T6 certificate

## Technical Data

Enclosure material:	PP+Carbon steel
Mechanical installation:	Bajonet (to be insert into IP65 enclosure)
Electrical connection:	6 pole plug-in connectors
Working temperature:	-30 to +80°C
Power supply :	2 wires 10÷30Vdc
Analog output:	4÷20mA
Measure range:	20pF÷10.000pF
Temperature compensation:	by ref. internal capacitor
Linearity:	0,5%
Calibration:	two push-buttons for self-acquisition
Certificate:	ATEX II 1 GD EExia II C T4...T6 IP65 T85°C
Display:	3 digit LCD



## TC30 General

2-wires LEVEL 4-20mA transmitter, digital technology, thermal-drift compensation. Swited for Ex-proof application.

### COMPACT VERSION

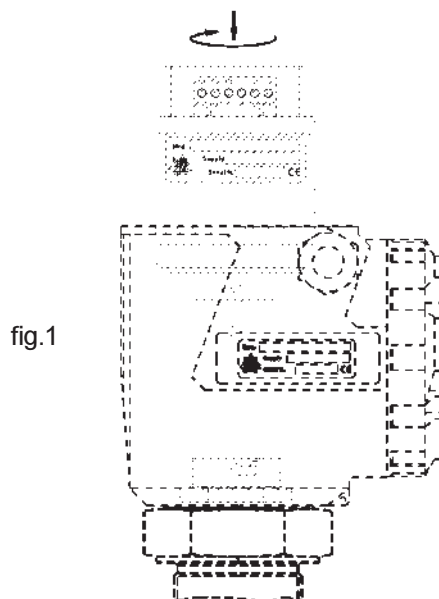

fig.1

## TC30 Mechanical installation

The TC30 insert must be lodge into the IP65 capacitance-sensor head connection.

Important to screw tight the cover of the head connection and the cable gland in order to grant the sensor IP65.

Thanks to the bajonet fixing-system, to insert or remove the TC30 from the head connection need to push and rotate.

Rotate clock-wise to fix into the head

Rotate reverse-clock-wise to remove from the head

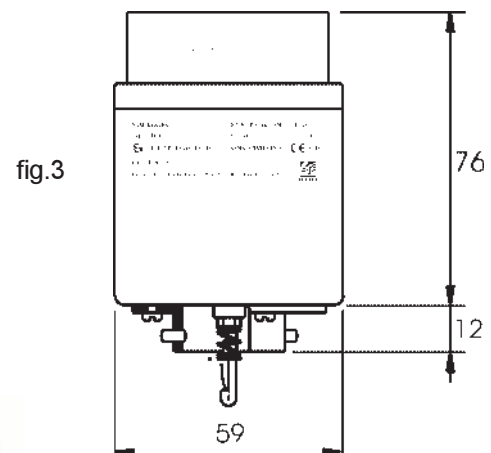

fig.3



## TC30 Electrical Connections

The TC30 capacitance transmitters have the following power-supply, electrical connections.

The TC30 capacitance transmitters are lodged into the sensor capacitance head connections; remove the cover unscrewing and opening the upper part, gain the access to 6-pole plug-in connector. Electrical connection must be made with a multi-wires round cable of proper diameter,

otherwise the seal of the cable gland may be impaired. No special cable or coax-cable are requests for compact version, and no practice distance limits. A special J-box with P1 and P2 calibration push buttons built-in is available on request for remote-calibration.

Always connect the electrode to vessel ground (PA). For this purpose there is a terminal on the side of the housing or on the mechanical connection. This connection is also used to supply the ground reference potential as well as to drain off electrostatic charges.

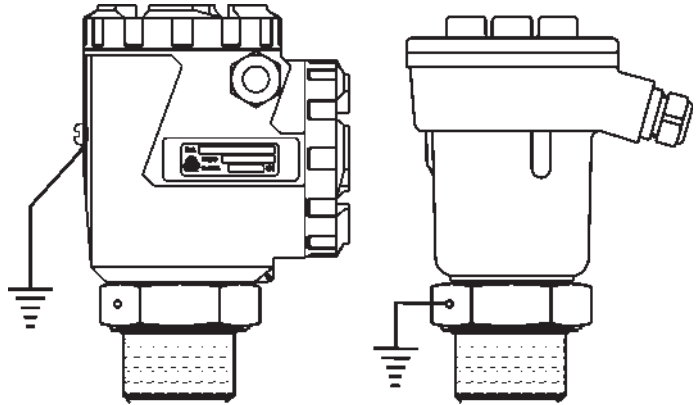
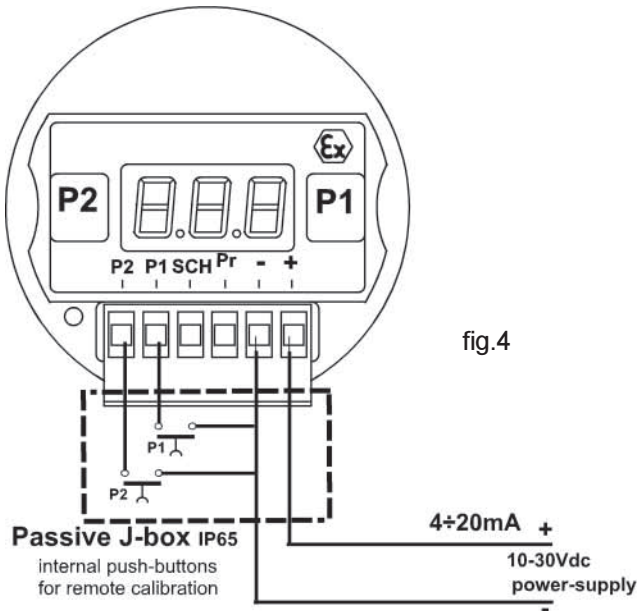

## TC30 - Installation

Ex-proof installation must be made according to the Ex-proof directive. The certificate was issued by KEMA:

**03ATEX1580 X**

**Ex II 1 GD EExia II C T4...T6 IP65 T85°C**

**Ui = 30V; li = 100mA; Pi = 0,75W; Ci = 0nF; Li = 0mH**

### Special conditions for safe use

The ambient temperature ranges and temperature classes are as specified under above (see tab.1).

For the models provided with an aluminium transmitter enclosure, the installation shall be such that ignition due to impact is avoided.

For the models provided with a nonmetallic transmitter enclosure, the installation shall be such that ignition due to impact is avoided.

The capacitive level probe shall be installed such that ignition due to hazardous electrostatic charges is avoided.

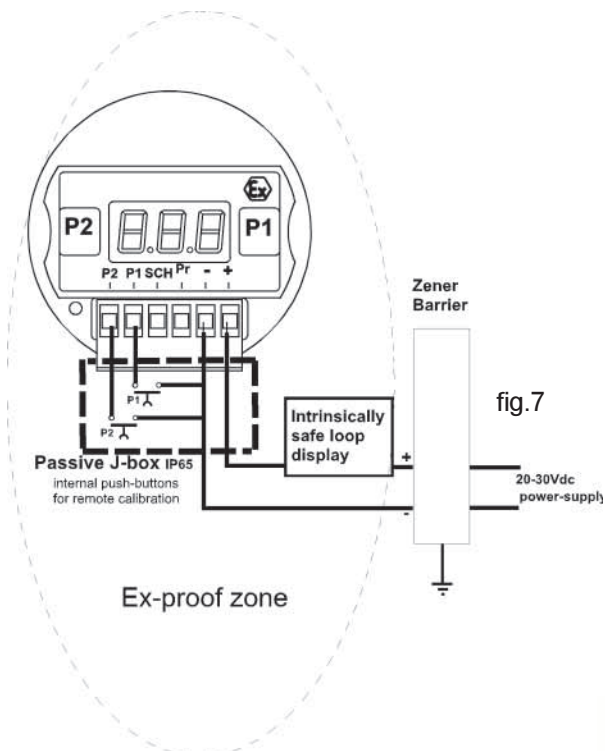

Tab.1

Ambient temperature range	Temperature class
-30 ÷ +40 °C	T6
-30 ÷ +55 °C	T5
-30 ÷ 80 °C	T4

## TC30 4÷20mA Calibration

**The TC30 calibration can be made by means the P1 and P2 push-buttons in two different procedures:**

To calibrate, needs to lodge the “TC30” into the head connection of the capacitance sensor installed into the vessel or tank in which needs the level measurement.

Depends to the possibility to reach easily 0% and 100% level is possible to use:

“Full-Empty Calibration”

or, when 0% and 100% level can't be reached

“High and Low-point Calibration” procedure can be used, see the next page.

**Important!** The calibration can be done first with empty and than with full (as the above procedure) or first with full and than with empty as well.

### Full, Empty Calibration(fig.9/10)

The TC30 transmitter can be calibrate in respectively at the level of 0% and 100% level, in order to memorise the relevant capacity electronically.

In the measuring mode, the TC30 has the “Mode decimal point” flashing.

**To calibrate 0% (4mA)** needs to have the level at the 0%.

Press simultaneously P1 and P2 (fig.9), release them and verify that “Mode decimal point” will stay fix lightened.

Press two times P1. The measured capacity has been memorised and associated to 4mA output.

Press simultaneously P1 and P2 again to switch in measure mode (Mode decimal point flashing).

**To calibrate 100% (20mA)** needs to have the level at the 100%.

Press simultaneously P1 and P2, release them and verify that “Mode decimal point” will stay fix lightened.

Press two times P2. The measured capacity has been memorised and associated to 20mA output.

Press simultaneously P1 and P2 again to switch in measure mode (Mode decimal point flashing).

### 4mA calibration - 0% level

fig.9

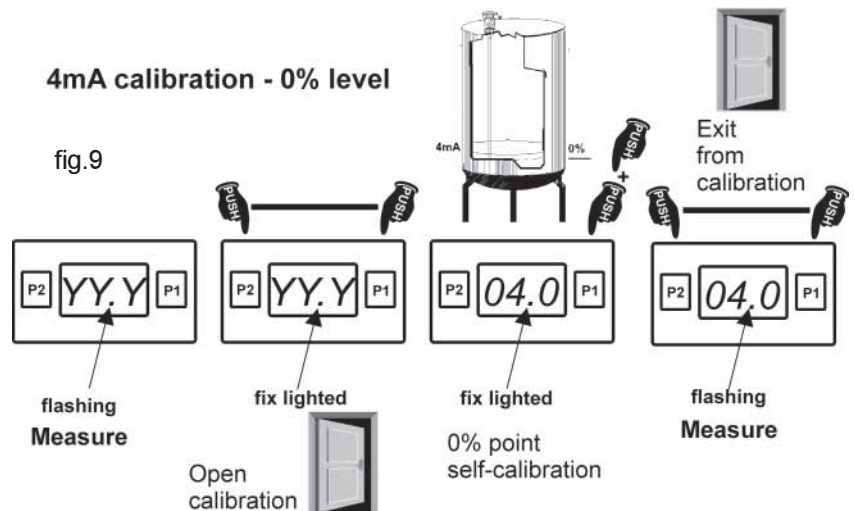

### 20mA calibration - 100% level

fig.10

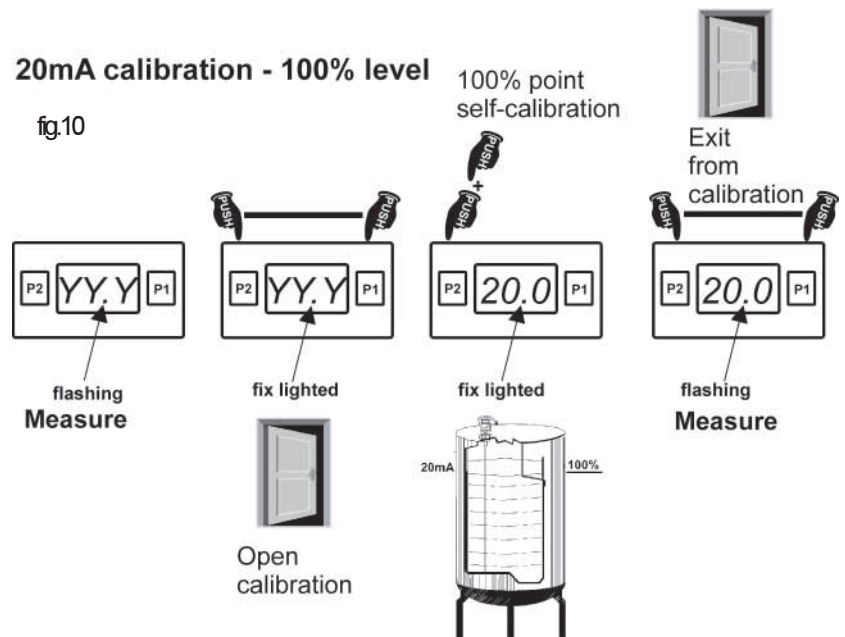

# TC30 4÷20mA Calibration (intermediate High-point , Low-point)

## High-point, Low-point Calibration

If only a limited level variation is possible, the calibration of the TC30 is still possible.

Need to connect a current-meter on the TC30 output current and verify the present level point at which make the calibration. Supposedly you are on the Low-point calibration, and the relevant level is 26%(8,16mA) than;

Press simultaneously P1 and P2 (fig.11), release them and verify that "Mode decimal point" will stay fix lightened, Open the calibration mode. Press two times P1. The measured capacity has been associated at the moment to 4mA output. Now, pushing few times the P2 key, increase the output current from 4mA to 8,16mA, (P1 decrease the value). Once the correct current-output is displayed in to the current meter; press simultaneously P1 and P2 again to Exit from calibration going in measure mode (Mode decimal point flashing).

Increase the level of your product as much as possible, for instance up to 58%(13,28mA) than;

Press simultaneously P1 and P2 (fig12), release them and verify that "Mode decimal point" will stay fix lightened, Open the calibration mode. Press two times P2. The measured capacity has been associated at the moment to 20mA output. Now, pushing few times the P1 key, decrease the output current from 20mA to 13,28mA, (P2 increase the value) ; press simultaneously P1 and P2 again to Exit from calibration going in measure mode (Mode decimal point flashing).

### Important!

The calibration can be done first with low-point and than with high-point (as the above procedure) or first with high-point and than with low-point as well.

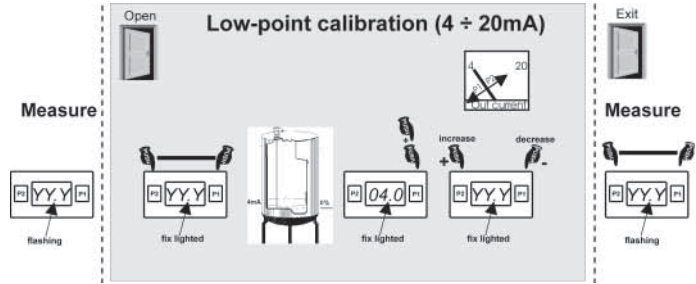

fig.11

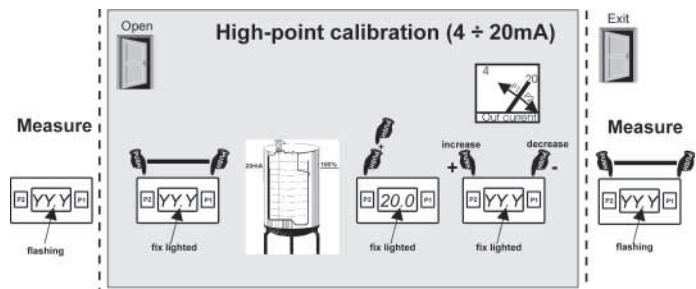

fig.12

## TC30 Warranty

Products supplied by SGM LEKTRA are guaranteed for a period of 12 (twelve) months from delivery date according to the conditions specified in our sale conditions document. SGM LEKTRA can choose to repair or replace the Product. If the Product is repaired it will maintain the original term of guarantee, whereas if the Product is replaced it will have 12 (twelve) months of guarantee. The warranty will be null if the Client modifies, repair or uses the Products for other purposes than the normal conditions foreseen by instructions or Contract. In no circumstances shall SGM LEKTRA be liable for direct, indirect or consequential or other loss or damage whether caused by negligence on the part of the company or its employees or otherwise howsoever arising out of defective goods.

## TC30 Factory test certificate

In conformity to the company and check procedure I certify that the equipment:

**TC30** Serial n. ....

is conform to the technical requirements on Technical Data and it is made in conformity to the SGM-LEKTRA procedure

Quality Control Manager

Production and check date



**SGM LEKTRA s.r.l.**  
Via Papa Giovanni XXIII, 49  
20090 Rodano (Milano)  
tel. ++39 0295328257 r.a.  
fax ++39 0295328321  
e-mail: [info@sgm-lektra.com](mailto:info@sgm-lektra.com)  
web: [www.sgm-lektra.com](http://www.sgm-lektra.com)