

WP-K1

Pressure Transmitter

825B090C

Features

- **Measuring Range:**
 - Gauge Pr.: Max. 0÷60MPa Min. 0÷1kPa
 - Absolute Pr.: Max. 0÷60MPa Min. 0÷20kPa
 - Negative Pr.: Max. -0.1÷1MPa
- **Power supply:** 12,5÷30Vdc (2-wired)
- **Output signal:** 4÷20mA
- **Overload Capacity:** 1.5 Times of F.S
- **Max. accuracy:** ±0.1%FS
- **Typical long-term stability:** ±0.1%FS per year
- **Operation Temperature:** -20° ÷ +80°C
- **Mechanical protection:** IP65
- **Max. adjustment scale:** "Zero" ±5%F.S.
F.S. ±20%F.S.

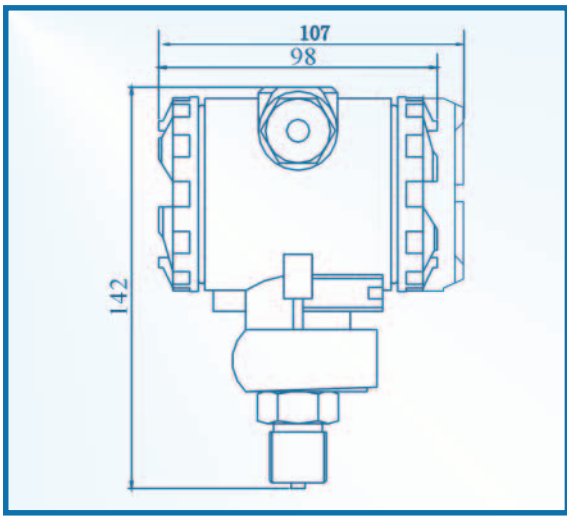

- 2-wired 4÷20mA transmitter**
- Pressure Classification: Absolute , gauge or negative**
- Accuracy: ±0.1% F.S.**
- Particularly heavy applications suitable**
- Any mounting positions compact transmitter**

General

WP-K1 Series Universal Pressure Transmitters adopt internationally advanced sensors and are assembled with highly accurate components. Its dry-pressure (without any liquid medium) measurement technology fully exert the advantages of ceramic sensors, and greatly contribute to the superior technological performance of overloading, small temperature offset, high stability and high accuracy.

WP-K1 Series Universal Pressure Transmitters are of a variety of output signals, ranges, process connections and materials, which resulted in suitable application in Petroleum, Chemical, Power, Metallurgy, Pharmacy and foodstuff industries under different conditions and medium. Therefore, they are becoming the ideal pressure measurement instrument for automation as well as perfect substitutes or upgrading products for conventional pressure gauges or pressure transmitters.



applied solution for the application

1. Power Supply and Output Signals

WP-K1 series pressure transmitters are powered by 24Vdc, and as for 2-wired transmitters with output of 4÷20mA, they can be normally operated during range of 5mA-30mA DC.

2. Technical Specifications

Material of Contact Part with Measured Medium:

Process Connection: AISI316L
1.4581
1Gr18Ni9Ti
Hastelloy C

Sealed Material: Flourin Rubber, FPM (Viton)
Butyl Rubber, IIR
Polyvinyl-4F: PTFE (Teflon)
Fully Sealed Welding

3. Adjustment & Calibration for “Zero” and Full-scale Output

Local adjustment with the “Zero” and “Span” trimmers in the housing.

4. Installation and Operation

WP-K1 series pressure transmitters can be installed on pressure joint of pipeline. A cut-off valve should be added between pressure joint and pipeline to make it easier for installation and debugging. The impact on “Zero” from the installation position can be well adjusted and calibrated.

5. Technical Specifications

Measuring Range: Gauge Pr.: Max. 0÷60Mpa Min. 0÷4kPa
Absolute Pr.: Max. 0÷2MPa Min. 0÷20kPa
Negative Pr.: Max. -0.1÷2MPa Min. -2÷2kPa

Overload Capacity: 1.5 Times of F.S

Pressure Classification: Absolute pressure, gauge pressure or negative pressure

Accuracy: Typical: ±0.1FS; ±0.2FS; ±0.5%FS (Including non-linearity, sluggishness and repetition)

Long-term Stability: Typical: ±0.1%FS per year; Max. ±0.2%FS per year

Tolerant Temperature: Normal Operation Temperature: -20°÷ +80°C
Membrane: -20°÷ +80°C (even up to 130°C at a short time)
High & Low Temperature: -65°÷ +150°C; 10°÷ +200°C; 10°÷ +350°C

Storage Temperature: -40°÷ +80°C

Relative Humidity: 0÷100%RH



6. Outline Dimensions and Mounting Dimensions

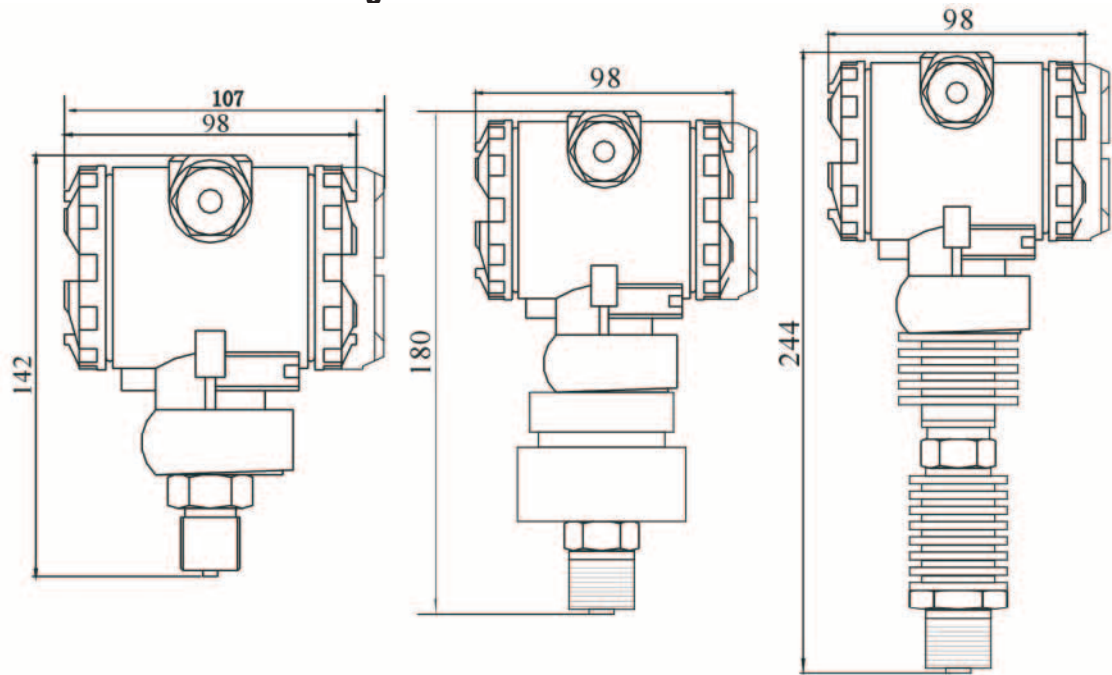

7. Process Connection

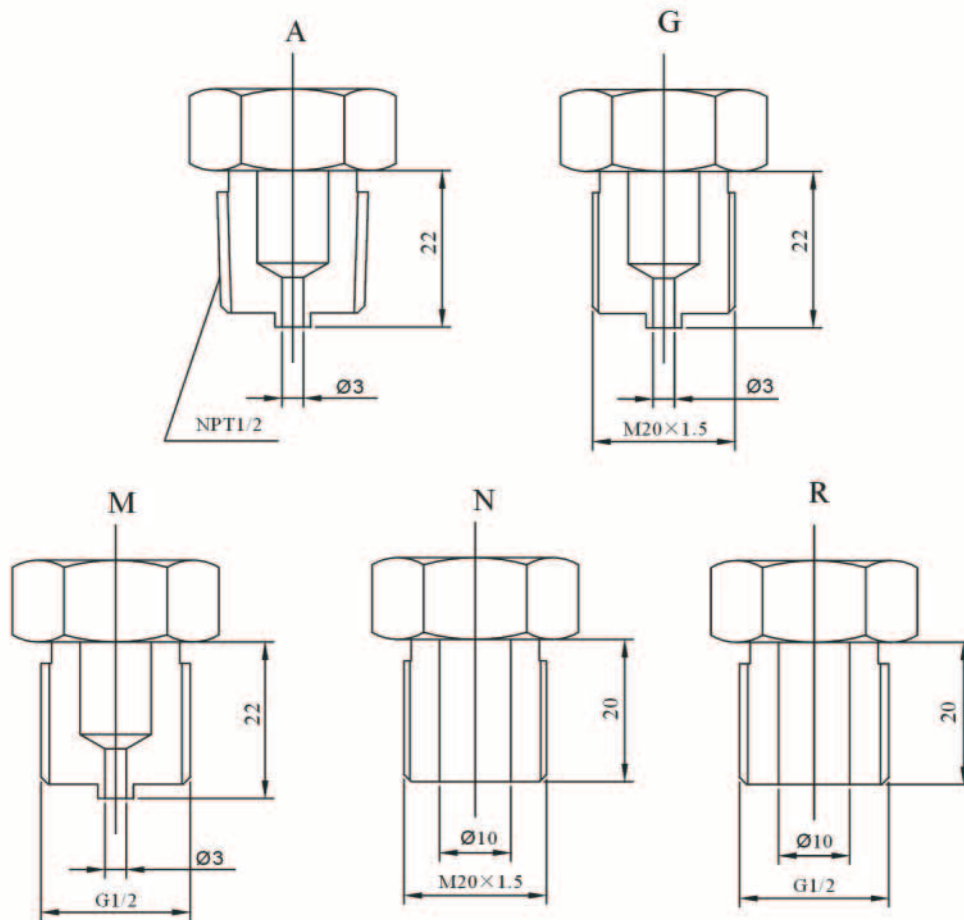

WP-K1 - Model Table

WP-K1 Pressure transmitter										
Code	Membrane type									
A	Si-diffused sensor: A1 standard; A2 ultra-stable, A3 Sanitary(Flat with membrane), A4 anti-corrosive(Ta Material)									
B	High or Low Temperature: -65°++150°C; 10°C+200°C; 10°+350°C									
C	Ceramic Capacitance									
Code	Certification									
D	Explosion Safe Exd II BT5 o Exd II BT6									
I	Intrinsic Safe Exia II CT6 or Exib II CT6									
S	None									
Code	Process connection material									
1	Stainless Steel 316L									
2	Stainless Steel 1.4581									
3	Stainless Steel 1Gr18Ni9Ti									
4	Hutchinson alloy C									
9	Special									
Code	Process connection									
A	Screw Thread 1/2NPT (small hole)									
G	Screw Thread M 20×1.5 (small hole)									
M	Screw Thread G½" (small hole)									
N	Screw Thread M 20×1.5 (big hole)									
R	Screw Thread G½" (big hole)									
Y	Special									
Code	Sealed material									
1F	Fluorin Rubber: FPM (Viton)									
2F	Butyl Rubber: IIR									
3F	Polyvinyl-4F: PTFE (Teflon)									
4F	Fully Sealed Welding									
Code	Output									
2	2 wire 4÷20mA									
9	Special									
Code	Display									
A	None									
B	100% linear									
C	0÷100% Digital LCD									
D	0÷100% Digital LED									
Y	Special									
Code	Accuracy									
1	0,1%									
2	0,2%									
5	0,5%									
9	Special									
Code	Measure range									
xxx	Please see "Standard Range Table of WP-8" series pressure transmitters									
Code	Measured pressure									
A	Absolute Pressure									
B	Air-proof Reference Pressure(please provide reference pressure)									
G	Gauge Pressure									

WP-K A S 1 G 1F 2 A 5 G17 G

Note: Si-diffused transmitter range for Standard and Sanitary are: Min. 0÷20kPa, Max. 0÷35Mpa. The range for stable pressure transmitter is: Min. 0÷10kPa, Max. 0÷60Mpa.; The range for Ø32ceramic capacitance transmitter is: Min. 0÷1kPa, Max. 0÷4Mpa.

WP-K1 - Standard range table

Gauge	Absolute	Measuring Range	Adjustment Range	Si-diffused or High Temperature Overload	Capacitance	Si-diffused	High & Low Temperature
G01	N	0÷4KPa	1.6÷5KPa	6.0KPa	N	N	Y
G02	N	0÷6KPa	4÷10KPa	9.0KPa	N	N	Y
G03	N	0÷10KPa	4÷20KPa	15KPa	N	Y	Y
G04	N	0÷16KPa	6.4÷20KPa	25KPa	N	Y	Y
G05	A01	0÷20KPa	8÷35KPa	30KPa	N	Y	Y
G06	A02	0÷25KPa	10÷35KPa	40KPa	N	Y	Y
G07	A03	0÷30KPa	12÷35KPa	45KPa	N	Y	Y
G08	A04	0÷35KPa	14÷35KPa	55KPa	N	Y	Y
G09	A05	0÷40KPa	16÷70KPa	60KPa	N	Y	Y
G10	A06	0÷60KPa	24÷70KPa	90KPa	Y	Y	Y
G11	A07	0÷100KPa	40÷100KPa	150KPa	Y	Y	Y
G12	A08	0÷160KPa	64÷200KPa	250KPa	Y	Y	Y
G13	A09	0÷200KPa	80÷200KPa	300KPa	Y	Y	Y
G14	A10	0÷250KPa	100÷350KPa	400KPa	Y	Y	Y
G15	A11	0÷400KPa	160÷700KPa	600KPa	Y	Y	Y
G16	A12	0÷600KPa	240÷700KPa	1.0MPa	Y	Y	Y
G17	A13	0÷1.0MPa	0.4÷1.0MPa	1.5MPa	Y	Y	Y
G18	A14	0÷1.6MPa	0.64÷2.0MPa	2.5MPa	Y	Y	Y
G19	A15	0÷2.0MPa	0.8÷2.0MPa	3.0MPa	Y	Y	Y
G20	N	0÷2.5MPa	1.0÷3.5MPa	4.0MPa	Y	Y	Y
G21	N	0÷4.0MPa	1.6÷4.0MPa	6.0MPa	Y	Y	Y
G22	N	0÷6.0MPa	2.4÷7.0MPa	9.0MPa	Y	Y	Y
G23	N	0÷10MPa	4.0÷10MPa	15MPa	Y	Y	Y
G24	N	0÷20MPa	8.0÷20MPa	30MPa	N	Y	Y
G25	N	0÷30MPa	12÷35MPa	45MPa	N	Y	Y
G26	N	0÷40MPa	16÷40MPa	60MPa	N	Y	Y
G27	N	0÷60MPa	24÷60MPa	90MPa	N	Y	Y
G28	N	-2÷2KPa	-1.6÷2.5KPa	N	N	N	Y
G29	N	-5÷5KPa	-3÷5KPa	N	N	N	Y
G30	N	-10÷10KPa	-6÷10KPa	30KPa	N	Y	Y
G31	N	-20÷20KPa	-13÷20KPa	60KPa	N	Y	Y
G32	N	-50÷50KPa	-33÷50KPa	150KPa	N	Y	Y
G33	N	-100÷60KPa	-66÷100KPa	250KPa	N	Y	Y
G34	N	-100÷100KPa	-66÷100KPa	300KPa	N	Y	Y
G35	N	-100÷150KPa	-100÷200KPa	400KPa	N	Y	Y
G36	N	-100÷300KPa	-100÷350KPa	600KPa	N	Y	Y
G37	N	-100÷500KPa	-150÷500KPa	1.0MPa	N	Y	Y
G38	N	-100÷900KPa	0.24÷1.0MPa	1.5MPa	N	Y	Y
G39	N	-100KPa÷1.5MPa	0.5÷1.9MPa	3.0MPa	N	Y	Y
G40	N	-100KPa÷2.0Mpa	0.5÷2.0MPa	3.0MPa	N	Y	Y
Z99	N	Special	Special	Special	N	Y	Y

Note: "N" means unavailable, "Y" means available.

Note: Special orders are all transmitters with membrane material of code A or B with pressure range below 20kPa and all transmitters with membrane material of code C with pressure range over 20MPa.



WP-K1 Warranty

Products supplied by SGM LEKTRA are guaranteed for a period of 12 (twelve) months from delivery date according to the conditions specified in our sale conditions document. SGM LEKTRA can choose to repair or replace the Product. If the Product is repaired it will maintain the original term of guarantee, whereas if the Product is replaced it will have 12 (twelve) months of guarantee. The warranty will be null if the Client modifies, repair or uses the Products for other purposes than the normal conditions foreseen by instructions or Contract. In no circumstances shall SGM LEKTRA be liable for direct, indirect or consequential or other loss or damage whether caused by negligence on the part of the company or its employees or otherwise howsoever arising out of defective goods.

WP-K1 Factory test certificate

In conformity to the company and check procedure I certify that the equipment:

WP-K1 part nb.

is conform to the technical requirements on Technical Data and it is made in conformity to the SGM-LEKTRA procedure

Quality Control Manager:

Production and check date:

SGM LEKTRA s.r.l.



SGM LEKTRA s.r.l.

Via Papa Giovanni XXIII, 49
20090 Rodano (Milano)
tel. ++39 0295328257 r.a.
fax ++39 0295328321
e-mail: info@sgm-lektra.com
web: www.sgm-lektra.com